

# Pilot



# Club Committee

- Chairman**      **Tony Yates**  
 ☎ 01784 449324  
 @ [chairman@messerschmittclub.org](mailto:chairman@messerschmittclub.org)
- Secretary**      **Alan Hitchcock**  
 ☎ 01364 240125  
 @ [secretary@messerschmittclub.org](mailto:secretary@messerschmittclub.org)
- Treasurer**      **Graham Taylor**  
 ☎ 01793 764770  
 @ [treasurer@messerschmittclub.org](mailto:treasurer@messerschmittclub.org)
- Regalia**      **Andy Carter**  
 ☎ 01623 407868  
 @ [regalia@messerschmittclub.org](mailto:regalia@messerschmittclub.org)
- Registrations**      **Alan Whitlock**  
 ☎ 01256 702606
- Membership**      **Mike Cooper**  
 ☎ 01400 262637  
 @ [membership@messerschmittclub.org](mailto:membership@messerschmittclub.org)
- Take Off Editor**      **Paula Cooper**  
 ☎ 01400 262637  
 @ [takeoff@messerschmittclub.org](mailto:takeoff@messerschmittclub.org)
- Web Site**      **Mark Hindell**  
 ☎ 0208 422 4943  
 @ [admin@messerschmittclub.org](mailto:admin@messerschmittclub.org)

# Area Representatives

- London/SE**      **Mark Hindell**  
 see above
- South**      **Alan Whitlock**  
 see above
- South Midlands**      **Alan Hitchcock**  
 see above
- East Midlands**      **Colin Burton**  
 ☎ 01623 481050
- South Lincs**      **Mike Cooper**  
 see above
- Wales**      **Chris Jones**  
 @ [cjwoodview@aol.com](mailto:cjwoodview@aol.com)
- Scotland**      **Graham Johnston**  
 ☎ 01968 660507

# What's All This?

By *Mark Hindell*

**W**ELL, THAT DEPENDS a bit on whether you are reading this from a paper copy or on a computer, but it's a bit of an experiment really; a one-off attempt to put together a Messerschmitt magazine collaboratively via the internet without ending up with something that looks like, well, like a printout of a web page. As such the name, Pilot, represents this experiment.

## Contents

1 Editorial	
Club Committee . . . . .	2
Area Representatives . . . . .	2
What's All This? . . . . .	2
KaRoScene . . . . .	3
On the cover . . . . .	3
Print Your Own . . . . .	4
2 News	
Events 2009/2010 . . . . .	6
Pub Nights . . . . .	7
Louth Lincs Wolds Rally . . . . .	8
Sachs 200 Schematic . . . . .	8
3 Alan's Live Sachs Line	
News from Faringdon . . . . .	9
Messerschmitt Christmas Meal . . . . .	10
4 Articles	
Repairing a Cracked Steering Bar . . . . .	12
Before and After . . . . .	12
Cut, Fill and Level . . . . .	13
The Tale of Making Mats . . . . .	14

# KaRoScene

The screenshot shows the KaRoScene website interface. At the top, there's a logo for 'messerschmitt enthusiasts' club' and 'Club Diary Magazine Spares'. Below that, there's a navigation menu with 'Home', 'Take Off', 'January 2008', 'Volume 2008', 'No. 1', and 'A Visit to VOSA'. A search bar is visible on the right. The main content area features an article titled 'A Visit to VOSA' by Adam Qualls, dated 06/03/2008. The article text is partially visible, mentioning a Honda Spacey scooter engine and a spare sander. There are also images of a car and a 'TAKE OFF' magazine cover. A sidebar on the right lists 'Take Off' issues for June 2008, No. 3 and April 2008, No. 2. At the bottom, there's a 'Navigation' section with 'Photos' and 'VOSA Inspection' links.

Web site? What web site? You may or may not have tripped over the MEC's KaRoScene web site at [www.messerschmittclub.org](http://www.messerschmittclub.org), but it's been out there for a couple of years now and has been steadily accumulating articles and pictures. The name 'KaRoScene' is something you can thank Alan Hitchcock for, basically a pun on kerosene (aka paraffin or aviation fuel). It made me laugh so we stuck with it. Besides, it's sort of expected for web sites to have daft names. Google? YouTube?

We want the magazine to look as good as a commercially produced product

magazine production doesn't overwhelm the creative efforts of its contributors or become a burden on its editor. Putting a new issue together should be fun rather than a chore, and by using better and faster tools in production it will also be possible to turn the magazine out quicker meaning that it will be fresher and have more up-to-date news.

Finally, and perhaps most importantly we hope you'll provide us with some feedback. Does Pilot 'do it for you'? And for that we link back to the magazine's point of origin, the web site. Here you can leave messages for the magazine's writers, post comments on the articles and find additional material beyond that which appears in print. Alternatively you can send email to [pilot@messerschmittclub.org](mailto:pilot@messerschmittclub.org).

So there it is. As an experiment perhaps not as grand as the Large Hadron Collider, but then, it didn't cost so much either.

Thanks for reading.

Mark and Alan

All the source material for this magazine started its life on the MEC website ([www.messerschmittclub.org](http://www.messerschmittclub.org)) and is released concurrently with the printable version.

Fundamentally of course we hope to have produced something that is enjoyable to read with useful and informative content. Isn't that the core objective of any magazine? But beyond that we've got a number of other goals.

While the quality of the content is paramount, we also hope to achieve a high print quality, with good quality typesetting, layout and photographs. We want the magazine to look as good as a commercially produced product, so if you're reading a paper copy then we hope that's what you find.

By assembling the magazine on the web site we've tried to streamline and distribute the production system so that the labour of

## On the cover

SOME OF YOU may well know Martin McKeever and his ever growing collection of microcars that includes, among others, a Berkley T60, Scootacar Mk1, a Goggomobil, Nobel 200, numerous Bond Minicars, and... a rather nice KR200. Having a large collection of cars is nice and all, but presents our man with the problems that he needs somewhere to keep them and, distressingly, he can only drive one at a time. The later is usually addressed by periodically roping in some friends to drive out for lunch or to visit something interesting. You can find the gory (somewhat more gory than usual actually) details of the most recent expedition at [www.tinthing.net](http://www.tinthing.net). The last time I drove this car it needed a bit of 'adjustment' to the brakes, but these days it's much more civi-

## Print Your Own



Fancy printing your own copy of Pilot? Go ahead, that's what it was made for. Although it's perfectly possible to

read Pilot on a computer either online at [www.messerschmittclub.org](http://www.messerschmittclub.org) or offline with a PDF reader (like Adobe Reader — [get.adobe.com/reader/otherversions/](http://get.adobe.com/reader/otherversions/)) you can't do that in the bath so easily.

The magazine has been set to print best in an A5 format by printing the pages on A4 paper using a standard inkjet or laser printer and then folding them in half. Quite a lot of printer software offers the option to do 'Booklet' printing like this.

Alternatively you can download a ready made booklet version of the magazine that you can send straight to your printer: [messerschmittclub.org/karoscene/epublish/4/14](http://messerschmittclub.org/karoscene/epublish/4/14).

BUT... whichever way you do it don't forget that if your printer can't print double sided pages then you must print the odd pages first, then flip them over and put them back through the printer to print the even pages. Some more printing details can be found at [messerschmittclub.org/karoscene/node/447](http://messerschmittclub.org/karoscene/node/447).

Stapling the pages is left as an exercise for the reader.

lized and thanks to a rebuilt engine and one of Russell Church's B&Q table leg exhausts it goes rather well. My only slight quibble with this was that it fell off after a mile and a half ("hmmm, you really do need something to lock the exhaust nut you know").

In fact trying to hold on to your exhaust is a sport with a long tradition for 'schmitt owners.

---

In fact trying to hold on to your exhaust is a sport with a long tradition for 'schmitt owners.

---

The vibrations that the engine produces seem to be enough to loosen even to most murderously tightened exhaust nut, and the application of pastes and sealants never

seems to do the trick. And once the exhaust has parted company with the cylinder head it can be a !@\*?% to get back on as it is a) extremely hot (obviously) and b) tucked away in a hard to reach spot between the cylinder and the firewall. Even once you have managed to successfully feel the nut back onto the manifold thread (and not drop the gasket) and take it up to being hand tight it's almost impossible to get a tool on it to tighten it up properly. Really the only time you get to properly attach the exhaust is with the engine down, and there have been times when I've preferred to drop the engine at the roadside rather than continue mucking about with it as this generally only takes ten minutes or so.

My ultimate solution which has served



### Martin McKeever's KR200

very well for many miles is simply a jubilee clip around the neck of the exhaust. This has a 'finger' riveted to it that reaches up and engages with one of the slots in the exhaust nut. This gives just enough restraint to keep the nut from turning. After refitting the exhaust, and especially if a new gasket was used, it generally needs re-tightening

after a few weeks use as the gasket crushes a bit.

Source URL:

[messerschmittclub.org/karoscene/node/427](http://messerschmittclub.org/karoscene/node/427)



**Ready To Go?** *Deciding which of Martin's cars to drive*

# Events 2009/2010

☎ 01367 240125  
@ [alanbubblecars@hotmail.com](mailto:alanbubblecars@hotmail.com)

## 22nd December *Messerschmitt Christmas Supper*

England's Rose, Postcombe on the old A40 near J6 of the M40. We need to know if you are coming if you want Chrimbo food, arrive 7.30pm. Peter Darby

☎ 0118 3778174  
@ [peter.darby1@ntlworld.com](mailto:peter.darby1@ntlworld.com)

## 28th December *Brass Monkey's run from Ripley Castle to Bonny Bridlington*

Those pesky Maniacs got the last word in again!

@ [Jim.Jamieson2@virgin.net](mailto:Jim.Jamieson2@virgin.net)

## 10th January 2009 *The Nosh*

The MEC Chairman invites all 'schmitters to the traditional lunchtime first meeting of the year based at The Leathern Bottel, Lewknor, yards from J6 of the M40. Tony Yates

☎ 07973 448023  
@ [chairman@messerschmittclub.org](mailto:chairman@messerschmittclub.org)

## March/April *East coast opener at Brandesburton* Micro Maniacs

## 3rd May *Popham Classic Car Day*

at this festival of small aircraft. Always interesting, good aero/autojumble always attended by 'schmitters. Peter Darby

☎ 0118 3778174  
@ [peter.darby1@ntlworld.com](mailto:peter.darby1@ntlworld.com)

## 13th – 15th May *Louth Lincs Wolds Rally*

Camping at the West End Farm, Gt. Carlton (<http://www.westendfarm.co.uk/>). Micromaniacs, Jon Hunt.

@ [Jon.Hunt@Ntlworld.com](mailto:Jon.Hunt@Ntlworld.com)

## 30th May *MEC Rally*

incorporating the Two Stroke Rally at the Motor Heritage Centre, Gaydon, just off the M40, to which you access over the day inclusive in the entry. A chance to view many strange and one off machines. Other stokers welcome to join us. Alan Hitchcock

## 3rd – 6th June *NOTBAR weekend*

but yet to confirm Pately Bridge as a trip to the Lake District is being investigated. Micro Maniacs

## 18th – 20th June *Heinkel Trojan Club Ltd Rally 2010*

at Rivendale Caravan Park on the A515 between Ashbourne and Buxton. You will need to book in with deposit by April 10th to ensure a spot as this is a commercial campsite.

## 18th – 20th June *Messerschmitts raid Kemble Aerodrome weekend*

Details still forming on this camping/show event.

## 24th – 27th June *The North of England Microcar Rally*

details to come but with the National moving South West this year will be the big event of the year in these parts. Micro Maniacs

## 2nd – 4th July *Bath Rally*

Keynsham Rugby Ground. Wynford Jones

☎ 01823 490922  
@ [wyn@kr200.fsnet.co.uk](mailto:wyn@kr200.fsnet.co.uk)

## 16th – 18th July *MOC International Rally*

Plumpton Racecourse, East Sussex further details to follow. I am assuming contact to be Roger Clements

@ [apple@applethatch.fsworld.co.uk](mailto:apple@applethatch.fsworld.co.uk)

## 7th – 8th August *Tatra Register UK 9th Annual Rally*

Location T.B.A. : Second 'first full weekend in August' fixture, following the adoption of a fixed date at the 2008 AGM. No excuse for not getting the rally into your 2010 diary as soon as you have one!

@ [info@tatra-register.org.uk](mailto:info@tatra-register.org.uk)

## 21st – 22nd August *The Micro/Mini Car World Meet 2010*

Crystal Lake, Chicago, Illinois hosted by the well known collectors Ken and Sylvia

## Pub Nights

**Bristol Clubnight** 2nd Wednesday in each month. The Major's Retreat, Tormarton, just north of Junction 18 of the M4, 1st right off the A46 Stroud road, down to the crossroads, right into the village to find a proper local. Always 'schmitters at this one. Contact Alan Hitchcock

☎ 01367 240125  
@ [alanbubblecars@hotmail.com](mailto:alanbubblecars@hotmail.com)

**MOC South West/Wales** 3rd Monday of every other month. The Fox and Hounds, Little Canford. Bottom roundabout on the A31 Wimborne. Contact Colin Archer

☎ 01202 734207  
or Peter Houghton  
☎ 01202 897594

**NEW General meeting MEC/Heinkel-Trojan OEC Ltd.** 3rd Wednesday of each month. The Fleece Inn, Bretforton, Nr Evesham, Worcestershire and therefore covering (in the broadest sense) Worcestershire, Herefordshire, Gloucestershire, Oxfordshire, Warwickshire, and Wiltshire. Classic car meeting in the summer behind pub. Contact Tony Yates

☎ 07973 448023  
@ [mec.mail@virgin.net](mailto:mec.mail@virgin.net)

**MOC South Eastern** 3rd Wednesday of each month. Three Crutches, Strood, Kent, close to the junction of the A2 and M2. Contact Mark Snowden

☎ 01634 309292

**Messerschmitt OC Eastern Area** 3rd Thursday of each month. The Queens Theatre, Billet Lane, Hornchurch, Essex. Contact Mick Morton (phone before attending)

☎ 01708 475662

**MOC Nottinghamshire** Last Wednesday of each Month except December. The Horse and Groom, Linby. MEC contact is Colin Burton

☎ 01623 481050

**NEW General meeting MEC South East Area. Last Tuesday of each month** Now fixed at England's Rose, Postcombe just a couple of miles from J6 of the M40. Contact Tony Yates

☎ 07973 448023  
@ [mec.mail@virgin.net](mailto:mec.mail@virgin.net)

**MOC Caledonian** Contact John Miller

☎ 01475 724229

Weger (Small Wonders Micro Car Museum). The target is to top 500 Micro and Mini Cars so we are talking BIG. Contact Marybeth Claypool

☎ +01 815 469 2936

web [www.worldmeet2010.com](http://www.worldmeet2010.com)

**27th – 29th August** DWAC Dutch Rally is expected.

**2nd – 5th September** The National Microcar

*Rally*

moves to Malvern at the Three County Showground. Early days but traditional format and backed by the Heinkel Trojan Club Limited specifically Ray Dilks and Nick Haddon.

## Louth Lincs Wolds Rally

**H**I ALL, the Micromaniacs would like to invite you all to the Louth Lincs Wolds Rally on the 13th to the 16th of May 2010, organised by Jon Hunt Esq. and helpers. We will be camping at the West End Farm, Gt. Carlton (<http://www.westendfarm.co.uk/>).

Also I hope to organise a meal out on Friday or Saturday and scenic testing road



runs, Friday Saturday & Sunday. There are about 15 Electric Points but we are allowed to Piggy-Back if you have the right connectors, and a few toilets and showers available. The nearest fuel garage is 9 miles away so a fuel can could be an idea?

More Info — [Jon.Hunt@Ntlworld.com](mailto:Jon.Hunt@Ntlworld.com)

Source URL:

[messerschmittclub.org/karoscene/node/445](http://messerschmittclub.org/karoscene/node/445)

## Sachs 200 Schematic

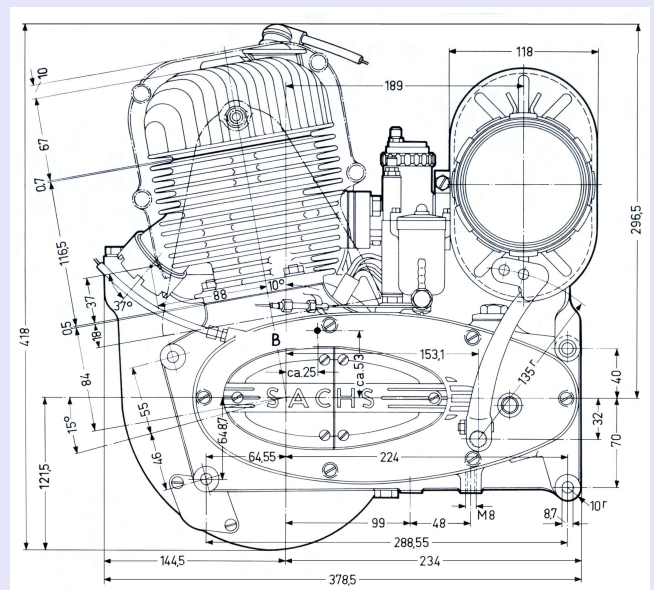

### Sachs 200 Schematic

**H**ERE'S ANOTHER very interesting piece of material from Big Al — a schematic of the Sachs 200 engine (I forget now where he said it came from). It was in pretty good condition, not too grubby, and scanned up nicely. A bit of cleaning and retouching left us with something that was clear enough to trace to produce a decent quality scalable graphic as a PDF. Click on the image to download it — you'll need a PDF reader such as Adobe Reader ([www.adobe.com/downloads/](http://www.adobe.com/downloads/)).

Source URL:

[messerschmittclub.org/karoscene/node/345](http://messerschmittclub.org/karoscene/node/345)

# News from Faringdon

By Alan Hitchcock

**W**ELL A LOAD OF WORK DONE and despite a spell of illness I am up to speed with my personal plan for the year. This did not involve use of Microcars but rather selling off the rest of the unwanted ones in the best condition I could reasonably manage to work them. This has been effected and I am down to just Messerschmitt and Goggomobil now. Even the last Heinkel has been traded off as I was offered a solid Fiat Jolly requiring rebuild, one of five left? To be honest, while I wanted to keep a Heinkel this very rare and valuable car could not be turned down and the Heinkel was not the model of the marque I really want to have in the collection; I want a coal scuttle boot rod change car. So the Jolly will be restored and sold at some point yielding enough cash to buy a suitable Heinkel and probably a healthy margin on top.

Along with clearing Microcars more big cars and the Puck have gone too. The shed and yard are beginning to look empty at last. However there are still some five cars to go plus ten or so scrap cars to shift, all by Christmas hopefully as then next year I have five 'schmitts to restore in a big effort to clear the decks of projects to a sensible level. That said I bought three more 'schmitts over the summer and another is due to arrive shortly. Three have left over the same period so a rotation and improvement of my collection has taken place. I find it odd that several of these cars were openly available, one even technically being sold, but no one had got on with a deal. Yet I keep hearing the moan that there are no 'schmitts available to buy. They have gone up guys! You cannot get a whole 'schmitt for under £5K really these days.

## Posh Sheds

I have a beautiful English Heritage Buildings oak frame 47-foot garage I contracted



**Fiat Jolly Giardiniera**

---

Yet I keep hearing the moan that there are no 'schmitts available to buy. They have gone up guys! You cannot get a whole 'schmitt for under £5K really these days.

---

to dismantle in Hampshire in the shed too. It took four days to shift with help from the BUMS. So once property issues are resolved I can rebuild this, which will house most of the remaining collection of cars allowing me to finally leave rented storage accommodation though in fact I might sublet it as it remains a cheap shed. Indeed if I stay in Faringdon with a double plot from the estate then I will have all I need on site as the workshop area is emptying slowly of unwanted spares and valuables. I should end up with a garage for a big car and a 'schmitt in store or as a workspace on a big car. The mid workshop will allow a 'schmitt through the door and is heated for year round work. I have a den beyond for clean work and possibly equipped with a wood burner scrounged off Tony Yates for aiding moving his cars from Chipping Camden. So a great area for differing works and hobbies. Two oak frame garages front and rear will take care of the entire collection and I may even install a flat in the upstairs of the house for a bit of income. If it works out it should do for me as a base.

## Messerschmitt Christmas Meal



**Location** — Proper pub, *England's Rose*, Postcombe on the A40 about 3 miles west of Junction 6 of the M40 at the foot of the Chilterns.

**Time** — Tuesday the 22nd of December arriving 7 to 7.30 pm (please note this is not the normal Tuesday of the meeting but a week early to avoid the holiday period).

**On offer** — A Christmas supper with trimmings for £10.00 and a chance to join the regulars at this monthly Messerschmitt meeting venue. Last year we could not eat it all. Since this is a pub not a restaurant we need to know numbers coming or you might find a shortage of traditional nosh. Pete Darby is liaising with the Landlady.

**Who can come** — Anyone who is interested in Messerschmitts and partners etc. and can pay their bill!

**Parking** — Do not panic if the front of the pub is full up. There is parking to the rear via an entrance a few yards down the road.

**Accommodation** — Yep they can do B&B at the Pub if you want it. I can put up two chums in comfort in Faringdon, after that you take your chances.

**Contact** — Peter Darby via [peter.darby1@ntworld.com](mailto:peter.darby1@ntworld.com) or 0118 3778174.

### Pub Nights

So I failed to appear at any rally this year save Bath. I have attended most of the three club nights near me. Tormarton continues and must be one of the oldest meets taking place on the second Wednesday of each month now at *The Major's Retreat* in the village where we can afford to eat! Mid month there is The Fleece at Bretforton which has been installed as a new pub night over the winter after a reasonable attendance at the classic car nights they run over the summer. This is a Microcar club night, not just 'schmitts, and takes in Worcester, South Birmingham, Stratford and down to Swindon and Gloucester as a catchment area. The date is to be confirmed but seems to be the third Wednesday in the month. An email to me ([secretary@messerschmittclub.org](mailto:secretary@messerschmittclub.org)) will put you on the list to be notified. Then there is England's Rose, Postcombe on the last Tuesday of the month where we

have a chomp and a chat. Otherwise during the day I have been busy and weekends tending to be clashes with customers or other business to be done. I am even not doing Mannheim, in part as I need no new stock at the moment but also the exchange rate is so poor.

All this rationalisation is going to have a clear knock on to the way I conduct my hobby in the future. I am gearing up for having cars in use but in operation from the home base. I have sold the Puck and the van will be going shortly. Citroen BX are being groomed for use as everyday transport. I am not really that interested in events that are based on fields of campervans anymore unless I decide to take that route myself. If so it will be using a rebuilt Buster Bubblevesal — the ultimate in bubble convertocamper technology complete with internal ramp so it can take two vehicles or turn into a workshop (had wondered about getting an

MOT licence for part time work and a mobile service at Bubblecar rallies). I wish to do daytrips out from home base as it maximises driving the classic yet controls time and expense and avoids being stood in a field in the middle of nowhere being bored after 10 o'clock at night. Hopefully I can get some of the local guys moving too and we can get a cell going where we visit each other and motivate getting cars going. Further I plan to have some non-Microcar classics in use so I can spread my local attendance wide yet remain in keeping with the event attended. Also, longer days out are possible in bigger cars as dogs can come too. Beyond that Doc and I are looking to start planning the Hebredian Tour in late April/early May by 'schmitt. This is something I have always wanted to do on a list of slightly odd adventures. They require a sorted car as they will, by definition, be unsupported trips using the cars as they used to be with accommodation of tent, B&B or scrounged. Because the locations are not mainstream I do not expect to be accompanied but Doc seems bent on joining the first trip. If it is a success then it might well be the west coast of Ireland the year after.

## Club

Not sure where the MEC fits in around all this activity on my hobby and business interests as I will be building up 'schmitts to sell each year and I have worked out a provisional building schedule converting plots to houses in Cumbria and then looking to perhaps do the same on a family in crisis property portfolio I bought cheap in Bristol in the summer depending on how it works out, as there is a mess of leases and covenants to sort out as the whole thing was mismanaged. Such an amount of work will leave little spare time and I will not be able to support much of the activity of the club on my own nor attend further flung events. Alternatively if the general election produces a Government incapable of solving our economic malaise with viable or radical policies I think it might be time to leave for pastures

---

I have suggested that in a few years the MEC might back a return of the National Rally to the 'Burford' format

---

new abroad. Clearly that will end my commitment to the club by default. As it is I will stand aside if someone wants to take on MEC secretary.

Indeed we have a very important round of meetings for the MEC coming up including an AGM to really get a grip on the future of this club. There are many differing options available but the dominant thing is the amount of input there is from people interested to be involved in organising stuff. At the moment we need some new blood to get things done as the incumbent folk are all too busy with their own activities. More on this shortly as interesting ideas are afoot, feedback is coming in, some outside the box. Yet ever looking forward I have suggested that in a few years the MEC might back a return of the National Rally to the 'Burford' format using The Cotswold Wildlife Park. We have a tentative booking of our rally being at the Two Stroke Rally at Gaydon on the 30th of May and a camping weekend on the traditional midsummer weekend in Derbyshire with the Heinkel Trojan Club. These are to be ratified. We have a Christmas Supper organised at Postcombe on the 22nd of December. Tony is about to announce The Nosh to be early in the New Year. I would like to see an event further south so that the Southern Coast guys can have a reasonable run out. So there is activity on your behalf but clearly based on where the organisers live and on venues offered elsewhere. We are happy to sponsor events pretty much anywhere if they have a sound chance of providing some fun for the local Micronauts.

Source URL:

[messerschmittclub.org/karoscene/node/420](http://messerschmittclub.org/karoscene/node/420)

# Repairing a Cracked Steering Bar

By Alan Hitchcock

**T**HE MESSERSCHMITT STEERING BAR is prone to cracking, especially on the side with the door strap which gets the wrong side of the bar putting undue pressure on that arm of the bar. It is also often the side which gets used to tweak the steering when the car is at standstill. So prevention is to always check the door strap into free position as you open the door by habit. Do not turn the steering unless the car is rolling. Do not let people sit in the car and turning the steering like a demented gibbon.

## Background

Several facts to know about steering bars: Early cars have a different, thinner steering

bar design to later cars — I think the change was about early 1958. The inner design and taper remained the same so they are interchangeable. The central boss is made of quite soft material containing the common taper insert. Through this and inside the outer moulded casing is a very tough bar of oval steel alloy — you would struggle to get a hacksaw through it! This assembly has a material somewhere between Bakelite and rubber moulded to it. The oval bar, though very strong, does flex and it is this flex that leads to the case cracking. Worse is that corrosion can get into the assembly and the casing is forced off by the expanding oxidation. A bar with corrosion is a difficult thing to restore just by filling. Also, be aware the case is quite brittle to impact. If the whole bar is dropped it is not unknown for the casing to shatter off in pieces.

---

If the whole bar is dropped it is not unknown for the casing to shatter off in pieces.

---

## Before and After



**In this case the steering bar is cracked on both arms and around the central recess...**



**but once filled and finished it looks great!**

Attempts to remake the steering bar have failed, as the oval bar is not simple to replicate. There was a scheme to remould reclaimed steering bars in Germany by Wolfgang Kraus but I do not know if it is still in operation.

## Removal

A cracked steering bar is not an MOT failure in Britain. This is because it is a handle bar not a steering wheel. In fact the cracks are really just unsightly as the oval steel bar takes all the strain and is probably the strongest bit of the car! The casing is repairable however and will sand and cut in a totally safe and predictable way using hand tools. To do this simply it is best to remove the steering bar from the column. However this is not as simple as it sounds, as normally special tools are required. This is because the steering column nut and column is shrouded by the design of the centre of the bar, which is at an angle to the plan

of the column. The taper needs considerable force to break it normally. So a peg spanner is needed to remove the soft metal steering centre nut and then a special puller with a correctly sized slot and a tough steel pin to clear the edge of the horn push hole yet with an end to fit flush on the column are required. Not using these risk destroying the nut with a screwdriver and hammer, ouch, and adding further cracks to the steering bar. Hammering the bar from the taper is a none starter really. The steering bar will be damaged and worse the taper can be hit damaging it for refit. Ill-fitting pullers can wreck the thread on the column and damage the edge of the horn hole. So size the job up before getting into difficulties. Tools can be bought or made. The peg spanner can be made from an old socket by cutting back the end leaving two parts now acting as pegs. The puller is trickier.

## Repair

Anyway, having got the steering bar to the workshop, on or off the column, clean up the areas to be repaired and gently remove the paint from the area with wet and dry. The recognised method is to then to cut a V shape opening up the crack. Clean out the dust and this can now be filled. Ordinary filler will not do, as it does not bond sufficiently to the remaining casing material. You need to use a product that has an epoxy glue element within in its specification. Otherwise your finished bar will crack in the same places as before. By choice you want a product that is workable when dry too. It is a bit of a trade off. I used to use raw Araldite 20 odd years ago, which prevented new cracks but was very hard to work into a perfect finish. Car filler is not tough enoughâ| I suggest testing before you commit yourself but I have found a two-part epoxy based ceramic filler, which works well.

In the pictures I have downloaded the restorer, Terry Cassem, has gone one stage further by running extra set of channels at 45 degrees to the original damage. This is to

## Cut, Fill and Level



**Cut** Make zigzag shapes across the cracks.

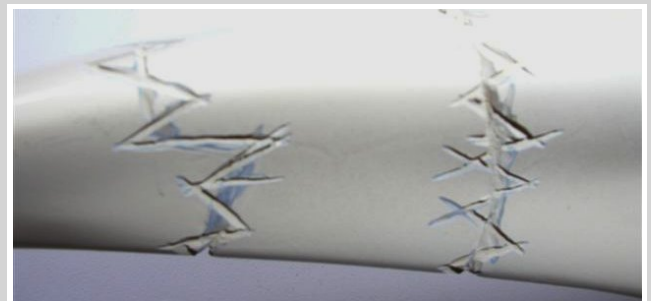

**Fill** Epoxy based filler is needed to bond the original material.



**Level** Excess filler is sanded down flush with the original surface. The original material is quite soft so go carefully.

aid the repair to tie together with the original material and create a stronger bond. Once dry the repair needs to be shaped. You can use fine wet and dry on the bar and the underlying material itself is black. Once the

profile is restored then it is a simple job to paint the steering bar. It is sensible to include the dismantled horn push in this so as everything is the same colour. Ford Opal white is a very close match to the original colour.

Source URL:

[messerschmittclub.org/karoscene/node/244](http://messerschmittclub.org/karoscene/node/244)

## The Tale of Making Mats

By Alan Hitchcock

**M**ANY MANY YEARS AGO, before Americans were Microcar enthusiasts and Britain still managed to look like it had an Empire a 'schmitter called Bob had an idea. This was because he went to a local show where he met Tom. Tom had restored an Austin Big Seven and made rubber mats for the running boards rather than use fibreglass ones. Bob thought, "Wouldn't it be nice if I could remake the rubber mats that all Messerschmitt KR200s, KR201s and TG500s were equipped with when they were new." He



knew that after 20 years most mats had long since fallen apart. Some cars had carpets, which got wet and made the car rusty, or even no floor cover at all which looked very ugly and all the 'schmitters were unhappy about it. Since Bob was a member of the MEC he went about this in a somewhat gentlemanly fashion rather than treating it as a business venture. You have to remember in these days men stuck to their word and tried to maintain certain standards rather than attempting to grab anything they could hopefully get away with.

### The First Mould

Bob met up with Tom at his Garage in Coalbrookdale where he restored classic cars for people like Lord Bradford of Weston Park. Now, Tom was able to make rubber mats as he knew people who had industrial equipment designed to do such things. Bob lent Tom an old mat that Peter Duran had lent to him to copy and the MEC paid for the work, which cost £930. Tom supervised the creation of a mould but in the process the rather crumbly mat that Peter had lent disintegrated and was no use anymore. Bob was not too upset because he was helping people. Anyway, Tom had a mould so now they could make new mats. Imagine Bob and Tom's disappointment when the new mat made from the new mould had a surface like sandpaper. This was not what they had planned. This mat also had Tom's garage name emblazoned on it. So Tom spent his own money and three days labouring to rebuild the mould so as to polish the surface to give a smoother finish. He then found out that the company he was using was bankrupt so he had to find another firm to make the mats.

A new run of mats was made without the

---

"Wouldn't it be nice if I could remake the rubber mats that all Messerschmitt KR200s, KR201s and TG500s were equipped with when they were new."

---

---

So Tom spent his own money and three days labouring to rebuild the mould so as to polish the surface to give a smoother finish.

---

garage name on and though not perfect they were good enough that other 'schmitters wanted to buy them for £75 each. The sales pitch was that after a few months use the worn ridges on the new mats made them indistinguishable from the originals when fitted in the car. Bob made no money from this and Tom only a little despite all the work he had put into the task. The MEC let Peter have a new mat to replace the lost original one. So everyone was happy.

One day Bob had to phone Tom. This was to tell him that a new batch of rubber mats were splitting. Bob had to sell seven mats off at half price. Tom went to the company who made the mats and asked for replacements. These were no good either and split in Tom's garage. Tom had an argument with the owner of the company. He was so annoyed he took the mould away from them as he found out they had not put enough of the third ingredient into the mix which made the mat elastic. The carbon and the silicon were not too expensive but to make extra money the expensive third ingredient had been cut short. Indeed, so bad was the argument and because Tom would not pay for the 10 replacement mats he had to go to court. It was a very unpleasant day and though he won his case because the mats were not saleable he made no money from winning and lost any money he might have made as he could not work that day and several others while he got ready to go to court. Tom was very upset by the whole thing too. Tom looked for a new company to make the mats.

### Fire!

Tom found a new company run by Paul who made the mats properly so once again Tom and Bob and all the 'schmitters were happy. Then Paul moved to a new factory.

This was fine until the factory caught fire and burnt down. The mould got burned too. Tom was upset but luckily the new company had insurance. This meant that the mould could be remade without Tom, Bob or the MEC having to pay for it again as it was not their fault that the mould was destroyed. Paul's company did the work and then some new mats were made. Well, Tom and Bob were very pleased, as these mats were very much better quality than any that they had made from the old mould. However this caused a problem: The new mould had cost £5,000 and the insurers took the view that the new mould was very much better quality than the old one. This is called 'betterment' and means that unless Tom, Bob or the MEC paid a balancing amount of money to the insurers then they would own part of the mould. Tom, Bob and the MEC did not want to pay more money. So Paul paid the betterment fee. This meant the new moulding tool had to be shared by the MEC who paid for the first one, Tom who repaired and improved the mould and Paul who paid the betterment fee for the replacement mould. But this did not really matter as Paul, with Tom's help made very good mats and the members of the MEC seemed to be very happy with them at the price they paid.

So for a long time Paul had mats made, Tom collected them until Bob could come by and take them to who ever wanted to buy or help to sell the mats on to the 'schmitters. The price was kept down, as Bob did not make any money from the mats though he was allowed two for all his unpaid work. Tom made only a little and soon retired from doing the maintenance and helping work as he was of retirement age and Paul made enough to be happy to make the mats without help. Everyone was very happy.

---

This was fine until the factory caught fire and burnt down. The mould got burned too.

---



**Tom Chitlow**

### Many Years Passed

Then some 15 years later a few mats got lost and several appeared that had not been sold by the MEC. By this time the MEC had different people helping to run it, Alan and Mike, who did not know the story so far. They were rather annoyed that they could not understand where the mats came from and how not all of them were coming to the MEC. Then they found out that the mats were coming from Chesterfield and not Telford where Paul had his factory. They decided to visit Chesterfield and find out what was going on as to them it seemed like there were two moulds and mats might be being stolen from the MEC.

At Chesterfield they met the very nice man who made the mats there. It turned out he was a friend of Paul's and he now made the mats for Paul from the only mould, which was stored there. Alan and Mike looked at the mould and it was in good condition as Paul had maintained it so it was perfect. So Alan and Mike went home knowing more than they had but still not enough to understand everything. Alan found out more about the mats not sold by the MEC and it seems that there had been a few bad mats that had been sold off and some others had

got lost in such confusion with people helping that no one new where they had really gone. It was not worth making more fuss other than to make sure that it did not happen again. So Alan asked Bob to tell him the story of the mats. Bob did and then said that as he was not around Telford much and that as Tom was retired and getting elderly it might be simpler to deal direct with Paul, though he had never met him, and to give Tom some money since he had a part share in the mould and had done a lot for us without really making very much money from it. Alan and Mike, being younger and having grown up doing business in the modern world with few gentlemen about found this a difficult idea. But when you read the tale of the mats you can understand why Tom might deserve some money. Paul can still make the mats and the members of the MEC and the 'schmitters can have well priced new mats to put in their cars for many a long day. Then Tom and Bob can live happily ever after having helped a lot of 'schmitters.

Source URL:

[messerschmittclub.org/karoscene/node/422](http://messerschmittclub.org/karoscene/node/422)

### The Fine Print

All material is presented in good faith and is copyright of its authors.

If anything you read here inspires you to modify your car, house, job or lifestyle then you do so at your own risk.

Contact details and events listings are as accurate as possible given available information at the time of publication.

<b>Editors</b>	<b>Mark and Alan</b>
<b>Writers</b>	<b>Mark and Alan</b>
<b>Listings</b>	<b>Alan</b>
<b>Layout</b>	<b>Mark</b>
<b>Typesetting</b>	<b>R. J. Drofnats &amp; Co.</b>